

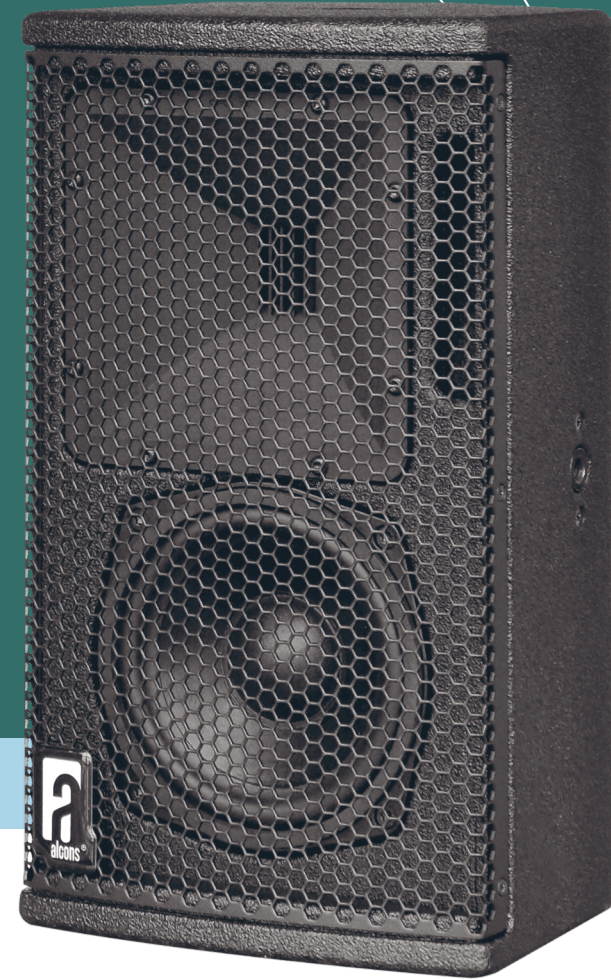

# VR5

mini versatile monitor

product manual



evolutionary audio solutions™

# Table of contents

1	<a href="#">Introduction</a>	3
2	<a href="#">Product Description</a>	4
3	<a href="#">Precautions</a>	5
4	<a href="#">Connection</a>	6
5	<a href="#">Installation</a>	9
6	<a href="#">Operation</a>	12
7	<a href="#">Accessories &amp; options</a>	16
8	<a href="#">Specifications</a>	18
9	<a href="#">Simulation</a>	21
10	<a href="#">Service and support</a>	24
11	<a href="#">Declaration of conformity</a>	25

# 1. Introduction

---

Dear customer,

Congratulations on your purchase of an Alcons Audio VR5 mini versatile monitor, and thank you for your confidence in Alcons products.

We are very honoured to welcome you to the growing family of Alcons ambassadors!

The Alcons systems are handmade with pride in The Netherlands, combining the latest production techniques and technologies with dedication and traditional craftsmanship.

Ever since its founding in 2002, the Alcons Audio team has been striving for the best possible sound reproduction for any type of source material and in any size of application. To get the best performance out of your Alcons system, please read the precautions section in this manual before installing and operating.

We wish you many happy listening hours!  
With best regards from the Alcons team,

Tom H. Back  
Managing Director

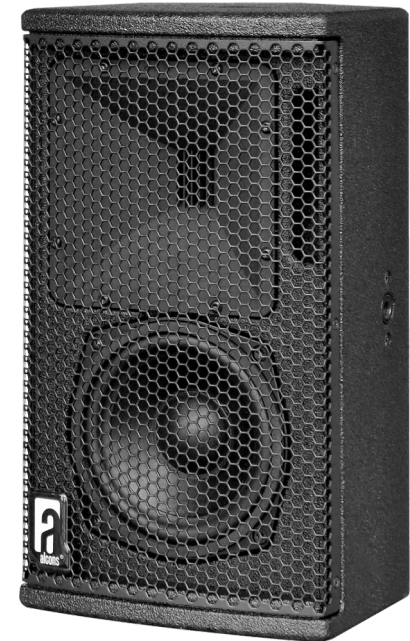

## 2. Product Description

---

### VR5 - mini versatile monitor

- RBN202 pro-ribbon HF driver with exceptional intelligibility and dynamic output
- Patented “Real-90” horizontal and “Real-60” vertical dispersion
- 1:1 non-compressed linear sound reproduction, with up to 90% less distortion
- SIS™ pre-wired for very high damping and further reduced distortion (with ALC)
- Ultra-compact, multi-angle enclosure provides versatile deployment
- All Neodymium drivers for excellent performance-to-weight ratio

The VR5 is a 2-way mini versatile loudspeaker, specifically designed for near-field applications where ultimate fidelity response needs to be projected with wide horizontal and vertical coverage.

The system brings the typical clear, dynamic and ultra-low distortion Alcons signature sound of the larger systems in a very small and unobtrusive package, for both portable and permanent applications.

The VR5 consists of the RBN202 pro-ribbon driver for HF and a dedicated-designed 5” mid-bass with Active Coil™ for extremely low-distortion LF reproduction. The VR5 HF section has a 500 W peak power input, enabling a 1:16 dynamic range with up to 90% less distortion from 1 kHz to beyond 20 kHz.

The patented (90-degrees) horizontal and (60-degrees) vertical dispersion of the revolvable waveguide, offers a wide and consistent coverage up to the highest frequencies; Very important for the imaging in stereo or immersive systems.

Due to the “compression-less” principle of the pro-ribbon transducer technology, the system has a fully linear response at any SPL, for an intuitive 1:1 performance.

For full system performance, the VR5 needs to be driven by an ALC controller-amplifier, delivering maximum sound quality with increased headroom and utmost operation reliability and flexibility.

The Signal Integrity Sensing™ pre-wiring ensures complete cable/connector compensation between the VR5 and ALC, significantly increasing response accuracy, regardless of cable length and system impedance, with tight and accurate mid and bass response as result.

The combination of the asymmetric multi-angle enclosure, the revolvable waveguide and the ACO™ color option provides for inconspicuous low profile stage, stand, wall or ceiling positioning. The 5 M10 mounting points enable swivel bracket, shoulder eye bolt and mic stand deployment.

Typical (short to medium throw) applications for the VR5 range from reference monitor, low-profile stage-lip/front-fill, stage monitor, under-balcony system up to a nearfield main PA system, in combination with a separate subwoofer. The BF121 subwoofer is a perfect companion for the VR5 monitor as super-compact PA system; It packs the same punch and accuracy as its bigger brothers BF151 and BF181 compact subwoofers.

### 3. Precautions

---

**Read this manual carefully before installing and operating your system. Retain this documentation for future reference.**

1. Due to the extremely low distortion performance of the Alcons sound systems, the experienced sound pressure level is higher than it appears. Prolonged exposure to high sound pressure levels can lead to hearing damage; Protective gear should always be available.
2. Work with qualified personnel for installing the system; Installation should only be carried out by qualified personnel who are familiar with the techniques, procedures and safety recommendations stated in this manual.
3. Ensure health and safety during installation and operation; All persons must wear protective headgear and footwear at all times.
4. Check conformity of any configuration and respect the maximum allowed values and the safety level recommended by Alcons Audio outlined in this manual.
5. Verify that the Working Load Limit (WLL) of all mounting hardware and accessories is respected. Alcons Audio is not responsible for any equipment and accessories provided by third party manufacturers.
6. Ensure that the surface is suitable for mounting a loudspeaker; Do not mount the loudspeaker assembly on unstable ground or surface. As a general rule, Alcons Audio recommends the use of safety straps at all times.
7. Do not make connections with the loudspeaker to the amplifier while it is switched on. Always shut off the amplifier when making connections to it, and mute the inputs when making connections to preceding equipment in the chain.
8. Do not operate the system in wet environments and protect it from excessive water or sun / UV exposure. The system has an IP43 rating and should be treated accordingly.
9. Regularly check the loudspeaker for damage to the transducers, cabinet and mounting points, as this can severely compromise the system's performance. Refer servicing to qualified service personnel. When in doubt, contact the factory on [support@alconsaudio.com](mailto:support@alconsaudio.com) .
10. Save the packing material. Should you ever need to ship the loudspeaker, use only the original packing.

## 4. Connection

---

The VR5 is a passive-filtered loudspeaker and features a high quality crossover network. As such, the VR5 requires one processing/amplifier channel for amplification. To activate the Signal Integrity Sensing™ circuit in the amplified loudspeaker controller (ALC), the use of a 4-core loudspeaker cable with NL4 Speakon® connectors is required;

The two extra wires are used for voltage sensing at the loudspeaker terminals. The output+ and sense+ wires are connected together at the loudspeaker+ terminal, and the output- and sense- wires are connected together at the loudspeaker- terminal.

The Speakon® connector is wired as follows:

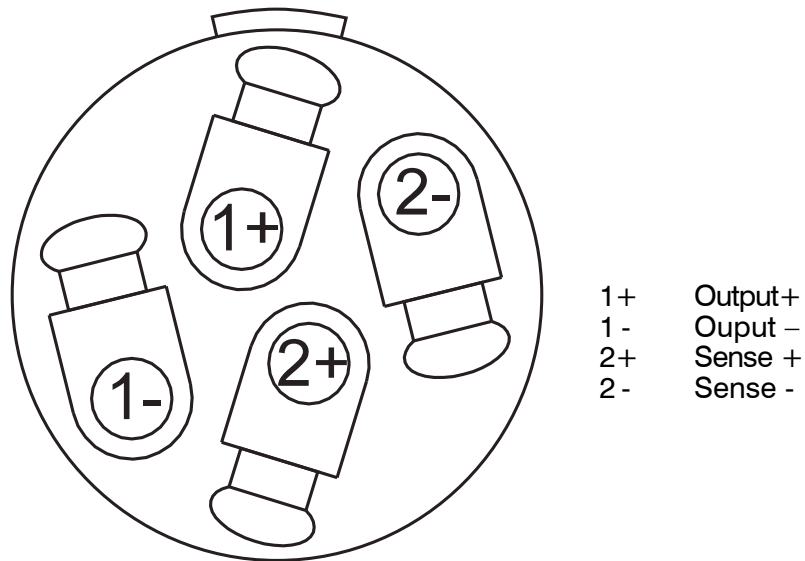

Speakon®male plug viewed from the wiring side

## 4. Connection

If you do not want to use the SIS feature at all, the sense wires should be connected to the output wires at the amplifier output in the Speakon® connector.

### Warning!

Never connect the sense+ to the output- terminal or vice versa, or short circuit both sense wires! Since you are disabling the amplifier's feedback network, the amplifier can produce a large amount of DC at its output. Through its protection circuitry, the Sentinel will shut-off and will not pass any audio.

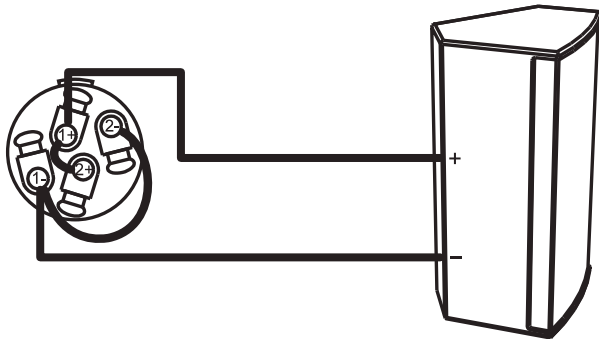

Loudspeaker connection without SIS™

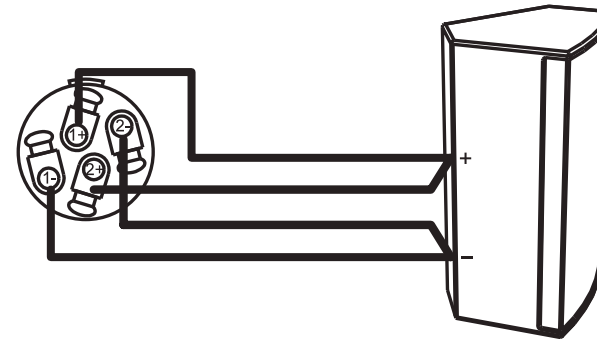

Normal loudspeaker operation

Use bridge mode when you want to combine the power of amplifier channel 1+2 or 3+4 into one loudspeaker load.

In bridge mode connect your loudspeaker with or without SIS to the channel 1 and channel 2 outputs (or channel 3 and 4) as shown above. Sentinel 3 only!

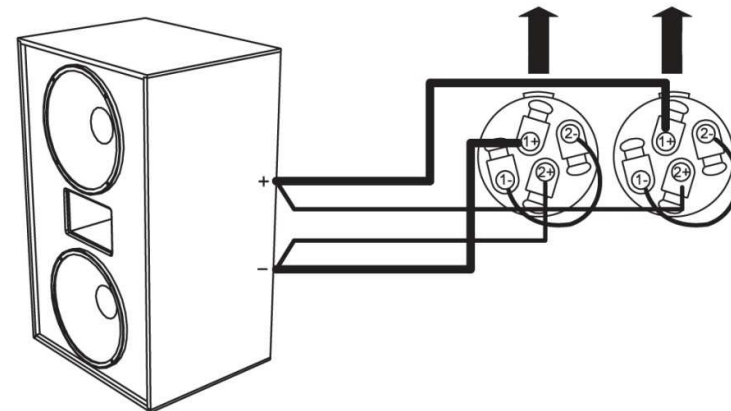

## 4. Connection

For a given loudspeaker impedance, the proportional power loss as a function of cable length and cable gauge is given in the next table:

	8Ω				4Ω			
	1.5 mm <sup>2</sup>	2.5 m <sup>2</sup>	4 mm <sup>2</sup>	6 mm <sup>2</sup>	1.5 mm <sup>2</sup>	2.5 m <sup>2</sup>	4 mm <sup>2</sup>	6 mm <sup>2</sup>
5 meters	1.4 %	0.8 %	0.5 %	0.4 %	2.8 %	1.7 %	1.1 %	0.7 %
10 meters	2.8 %	1.7 %	1.1 %	0.7 %	5.4 %	3.3 %	2.1 %	1.4 %
15 meters	4.1 %	2.5 %	1.6 %	1.1 %	7.8 %	4.9 %	3.1 %	2.1 %
20 meters	5.4 %	3.3 %	2.1 %	1.4 %	10.2 %	6.4 %	4.1 %	2.8 %
25 meters	6.6 %	4.1 %	2.6 %	1.7 %	12.4 %	7.8 %	5.0 %	3.4 %
30 meters	7.8 %	4.9 %	3.1 %	2.1 %	14.5 %	9.3 %	6.0 %	4.1 %
40 meters	10.2 %	6.4 %	4.1 %	2.8 %	18.5 %	12.0 %	7.8 %	5.4 %
50 meters	12.4 %	7.8 %	5.0 %	3.4 %	22.1 %	14.5 %	9.6 %	6.6 %

To calculate the SPL losses from these percentages in dB's, the following equation may be used:

$$\text{dB loss} = 20 * \log(1 - (\% \text{loss}/100))$$

In the next table a few percentages are converted to dBs:

% loss	dB loss
1 %	0.1 dB
2 %	0.2 dB
5 %	0.4 dB
10 %	0.9 dB
15 %	1.4 dB
20 %	1.9 dB
25 %	2.5 dB
30 %	3.1 dB
35 %	3.7 dB

“The VR5 has a 16 ohms impedance which makes parallel connection possible of multiple cabinets.

It is technically possible to connect up to 8 VR5 cabinets on one amp channel, with a resulting impedance of 2 ohms; However, we recommend not going any lower in impedance than 2.7 ohms, which is 6 VR5 cabinets in parallel, to provide ample power to each cabinet.

## 5. Installation

The VR5 is to be driven by the ALC controller-amplifier for full system performance, delivering maximum sound quality with increased headroom and utmost operation reliability and flexibility.

The operation reliability is guaranteed by the advanced limiting algorithms in the DSP; The values of the dedicated preset are based on the VR5 system surviving a 1000 hours durability test in the R&D test bunker at Alcons Audio HQ.

On the ALC, the correct VR5 preset needs to be selected. Go to the “Preset” tab; tap the button on the channel you wish to operate the VR5 with; A selection box will appear with the different series groups. (See fig 1) With the encoder select the “V-series”; then select “VR5”; (See fig 2) A confirm box will appear. (See fig 3). Repeat these steps for your 2nd loudspeaker (See fig 4)

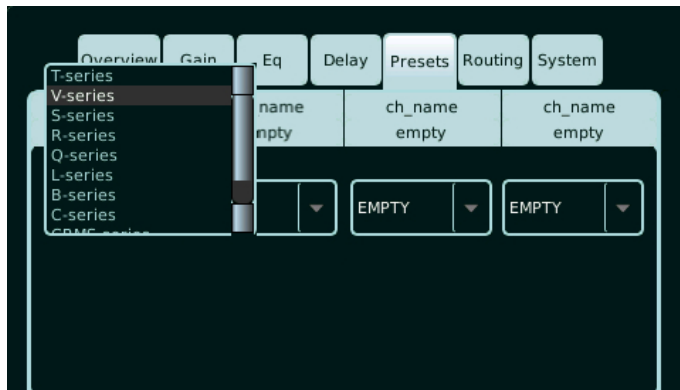

Fig 1. Select loudspeaker 1 > Select V-series

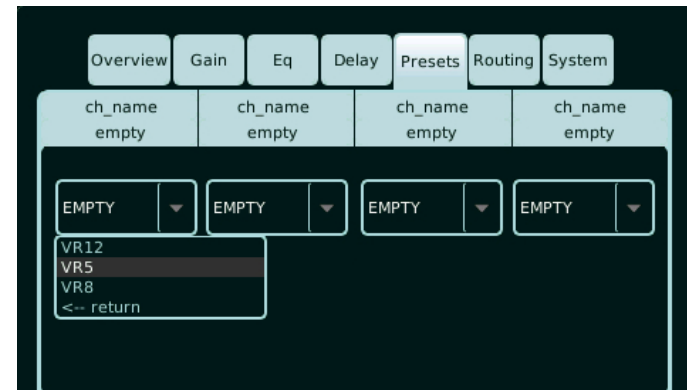

Fig 2. Select loudspeaker 1 > Select VR5

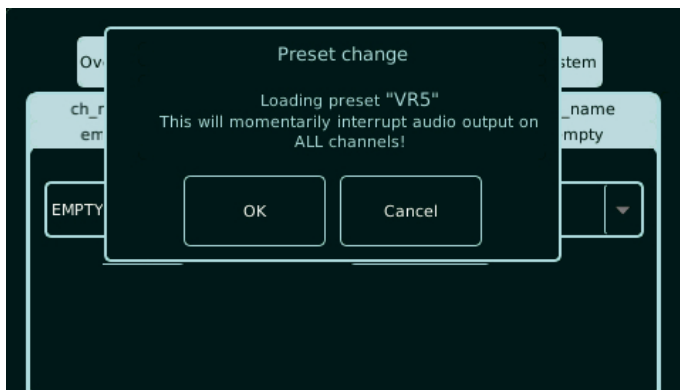

Fig 3. Select loudspeaker 1 > Confirm VR5, be aware of possible audio interruptions

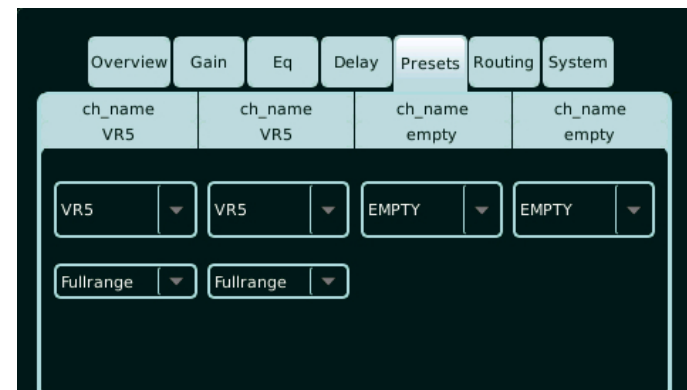

Fig 4. Select loudspeaker 2 > Repeat the previous three steps for your 2nd loudspeaker

## 5. Installation

Now the VR5 is dedicated to this channel; Next you can make a choice of filter settings within the preset: 80Hz high-pass, 100Hz high-pass or full-range operation.

The Alcons VHIR™ processing ensures a flat phase response down to 200Hz with minimal latency; This enables the user to select any Alcons subwoofer to seamlessly work with the VR5, with optimized phase response.

Optional settings in combination with a subwoofer (BF121 in example): The VR5 preset can be set on high-pass filtering at 100Hz, depending on the requirement (typically, the 100Hz setting is preferred in higher SPL applications).

To match the VR5 and obtain a flat system response, the BF121 preset needs to be set on the same frequency preset, 80Hz or 100Hz. (See fig 5)

In applications where the VR5 is positioned further away from the subwoofer, the VR5 preset may be set on full-range, with the accompanying sub set on 80Hz. (See fig 6)

### Optional settings:

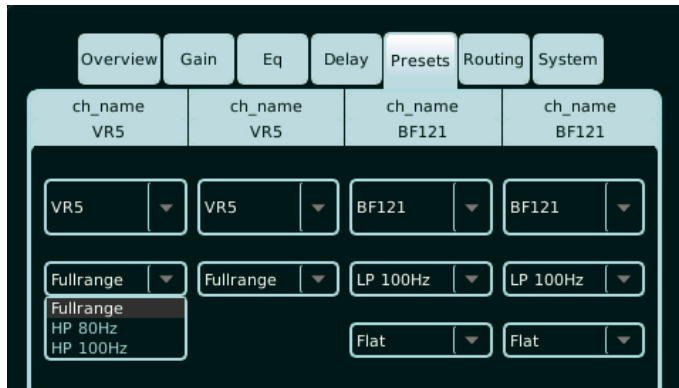

Fig 5. Range selection  
Select fullrange or HP at 80Hz or 100 Hz

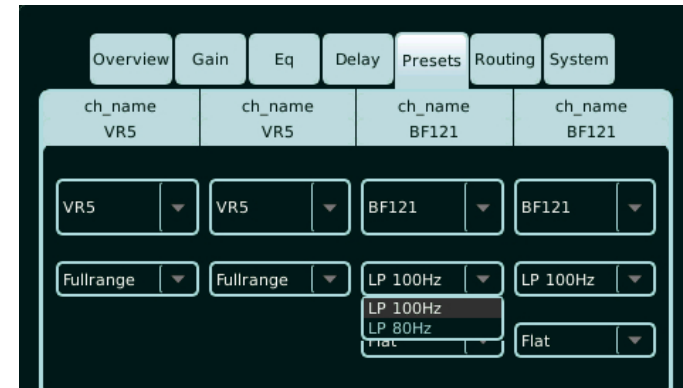

Fig 6. Low-pass filtering  
Optional setting for low-pass filtering at 80 Hz or 100 Hz

## 5. Installation

The dedicated factory VR5 preset ensures a flat frequency response; With the equalizer and delay sections in the ALC, the performance of the VR5 can be adjusted to the environment and application. (See fig 7) These settings can be stored in the on-board user-preset bank.

### EQ and Delay settings:

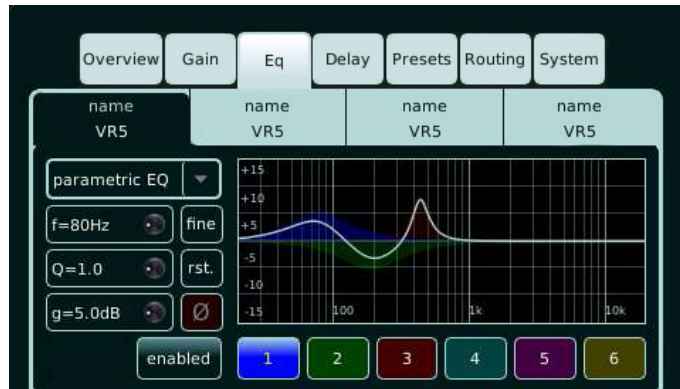

Fig 7. EQ  
Frequency adjustment per channel

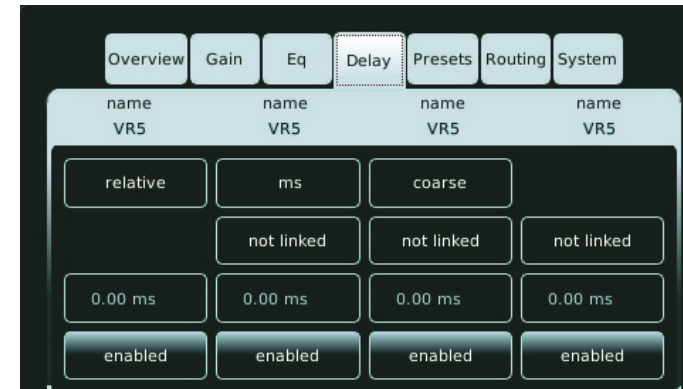

Fig 8. Delay  
Delay adjusting to fit the environment



### Warning!

Always make sure the correct system preset has been selected, before unmuting / starting-up the system, as operating with incorrect settings can severely damage the loudspeaker and voids warranty.

## 6. Operation

---

The VR5 is equally suitable for mobile deployment as well as fixed installation.

Due to the patented wide 90 x 60 degree HF dispersion, placement is less critical to still obtain a good audience coverage, both horizontally as well as vertically; However, it is recommended to focus the VR5 with its horizontal and vertical axis to the audience, so as to have the best projection, while minimizing spill outside the listening area.

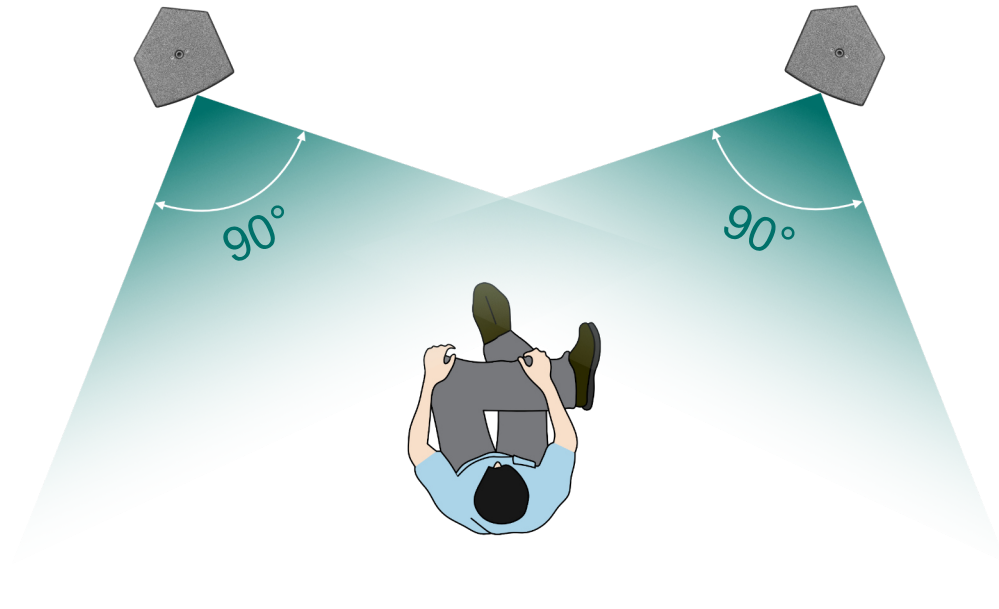

**Constant horizontal directivity = consistent full frequency audience coverage**

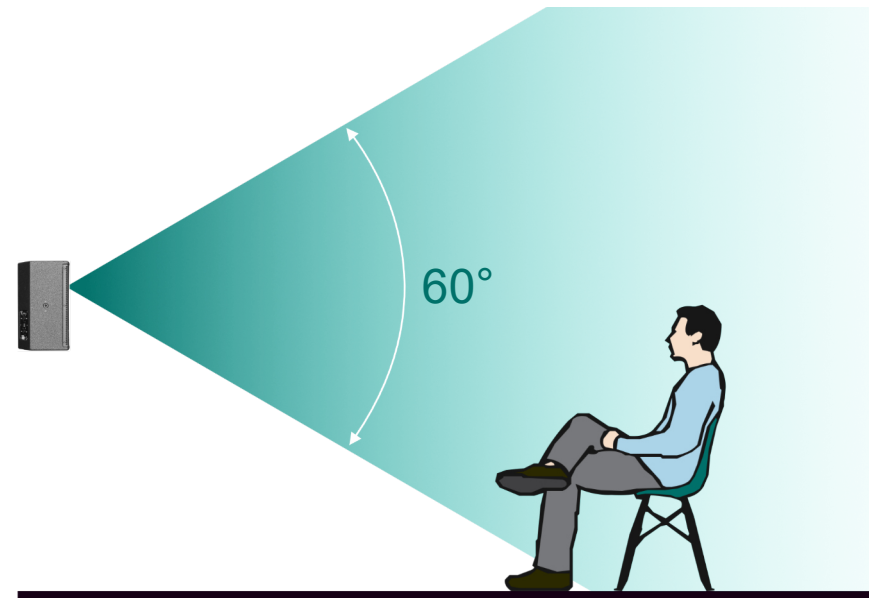

**60° vertical dispersion = wider sweetspot and audience coverage in close-field applications**

## 6. Operation

---

The dual-angle cabinet makes for a low-profile in different positions in case of ceiling mounting or use as a floor monitor.

The VR5 is also available in mirror-version, as VR5M, This cabinet shape is ideal in critical monitoring applications, to have a symmetric left/right system configuration. It also further expands the low-profile mounting options.

The 5 M10 mounting points enable the use of swivel brackets, shoulder eye bolt and microphone stand deployment to get the best positioning for the VR5.

### Mounting option examples:

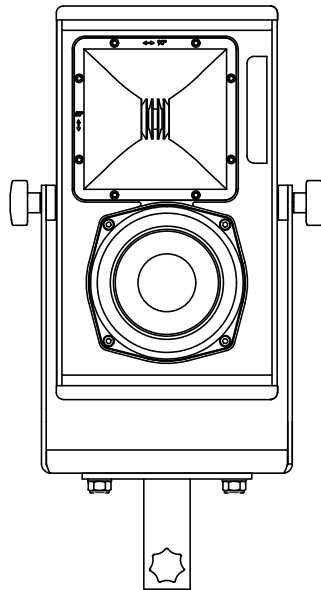

**Standmount w. pan/tilt**  
BRKVR5 + STMT

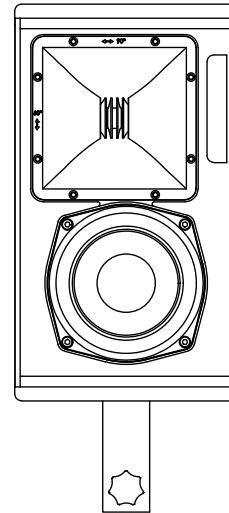

**Standmount non pan/tilt**  
reducer flange 36mm to M10  
thread (STMTM10)

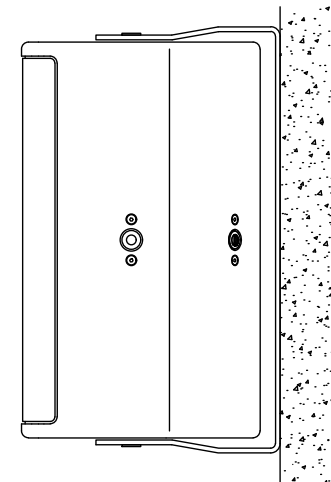

**Vertical mounting w. pan-only**  
BRKVR5HOR

## 6. Operation

---

### Mounting option examples:

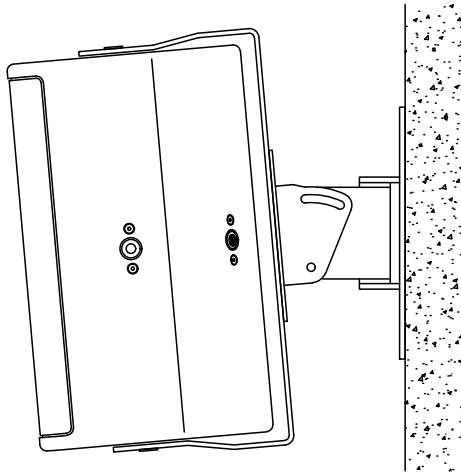

**Vertical mounting w. pan/tilt**  
BRKVR5HOR + K&M 24471 & 24358(AP5)

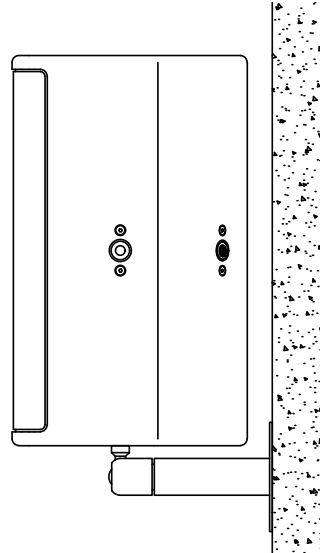

**Top/ bottom mounting**  
Vertical mounting with  
K&M 24185-317-55

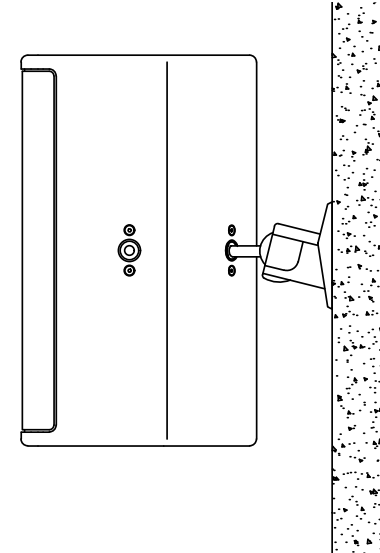

**Rear mounting w. pan/tilt**  
Multiple angles with Omnimount  
15.0W

## 6. Operation

---

### Mounting option examples:

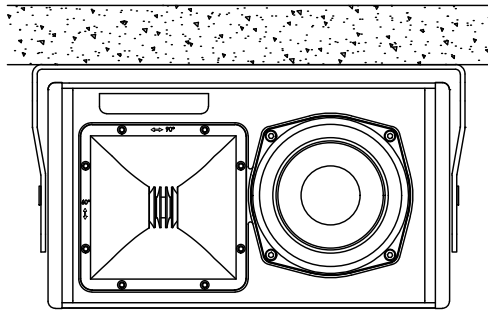

**Horizontal mounting w. tilt only (ceiling)**  
BRKVR5HOR

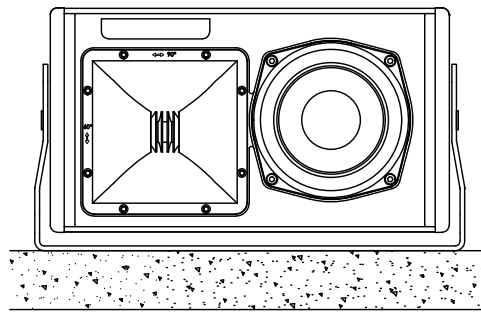

**Horizontal mounting w. tilt only (floor)**  
BRKVR5HOR

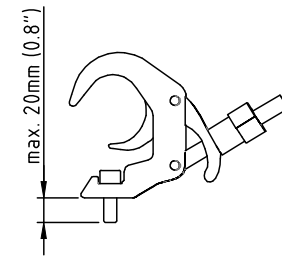

**Truss clamp**  
Thread length  
max. 20mm (0.8") below clamp.

## 7. Accessories & options

---

### Mounting options:



#### **BRKVR5**

The BRKVR5 is a swivel yoke for a single VR5 mini monitor.

The yoke is connected to the cabinet with two M10 knob bolts on the side of the cabinet.

The bracket can be fitted with an optional truss clamp, TV-spigot or STMT stand-mount adapter, with M10 (2) or M12 (1) bolt/nut connection.

The BRKVR5 is certified for a safety-rating of 10:1, for one cabinet VR5.



#### **BRKVR5HOR**

The BRKVR5HOR is a bracket for mounting a single VR5 monitor in horizontal position.

The yoke is connected to the cabinet with two steel strips on the side of the cabinet, secured with two M10 bolts each.

The bracket can be wall/ceiling mounted through two 8mm/0.3-in holes; The bracket can be fitted with an optional truss clamp, TV-spigot or STMT stand-mount adapter, with M10 (2) or M12 (1) bolt/nut connection. The BRKVR5 is certified for a safety-rating of 10:1, for one cabinet VR5.

## 7. Accessories & options

---

### Mounting options:



#### **STMT**

The STMT is a 36mm stand mount sleeve, enabling all swivel yokes to be used on standard tripod stands or mounting accessories with a diameter of 35mm.

It can be mounted on all BRK brackets, prepared for STMT, with two (2) M10 bolt/nut combinations. Includes a small diameter grip knob.



#### **STMTM10**

The STMTM10 is a 36mm stand mount sleeve, enabling speakers to be used on standard tripod stands or mounting accessories with a diameter of 35mm.

It can be directly mounted on the cabinet, with the M10 thread connection. Includes a small diameter grip knob.



#### **SHEBLTM10**

The SHEBLTM10 is a shoulder eyebolt in the size M10. The eyebolt can be used on all VR cabinets, fitted with M10 bolts.

Applications for the SHEBLTM10 are: flying cabinets or attaching additional safety steels.

## 7. Accessories & options

---

### ACO™ Colour option:



**ACO™** (Architect Colour Option)  
The VR5 can be finished in any of the 180+ colours from the European RAL™ colour scheme

### Transport options:



**FC2VR5**  
Flightcase for 2 pcs. VR5 + BRKVR5 brackets

Also available as:

**FC4VR5**  
Flightcase for 4 pcs. VR5 + BRKVR5 brackets

## 8. Specifications

---

### VR5 product views

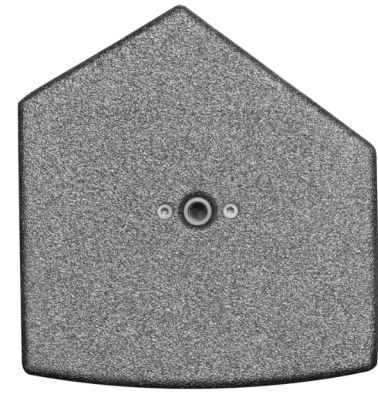

**VR5**  
Top/bottom

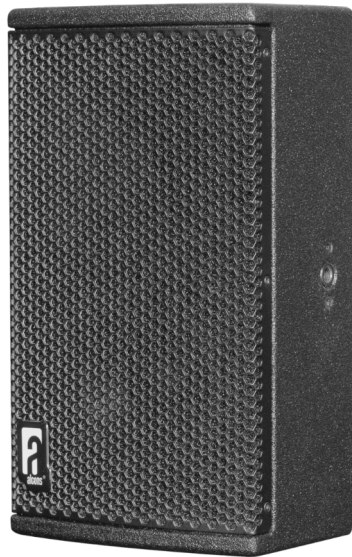

**VR5**  
Front



**VR5**  
Rear

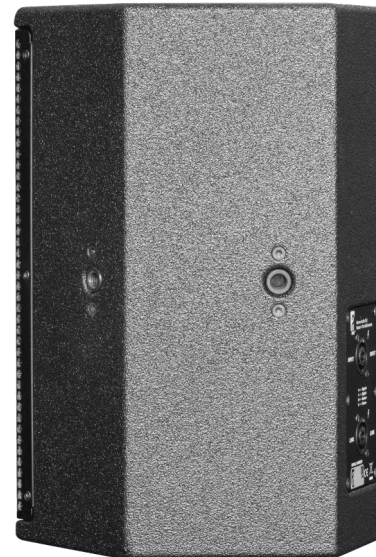

**VR5**  
Rear (side)



**VR5**  
Rear (side)

## 8. Specifications

Technical specifications	
Frequency response	67 Hz – 20.000 Hz (+/- 3 dB)
	59 Hz - (+/- 10 dB)
Sensitivity nominal	98 dB (200 Hz - 10 kHz)
Nominal impedance	16 ohms
Recommended drive	Sentinel3 min., max. 6 pcs. per channel (2.7 ohms)
Nominal SPL peak	121 dB (Sentinel3 200 Hz - 10 kHz)
	127 dB (Sentinel10 200 Hz - 10 kHz)
Dispersion H x V	90° x 60° or 60° x 90° (@ 20 kHz)

Physical specifications		
System	2-way, full-range	
Filtering	passive	
Driver LF	1x AMB5NDAIC-16 5" Neodymium, vented	
Driver HF	1x RBN202rs 2" pro-ribbon driver	
Connectors	2x Speakon NL4 input/link	
Physical dimensions	mm	inches
Height	339	13.3
Width	191	7.5
Depth	205	8.0
Weight (approx.)	6 kg	13.2 lb
Warranty	6 years limited	

## 8. Specifications

---

### Dimensional drawing

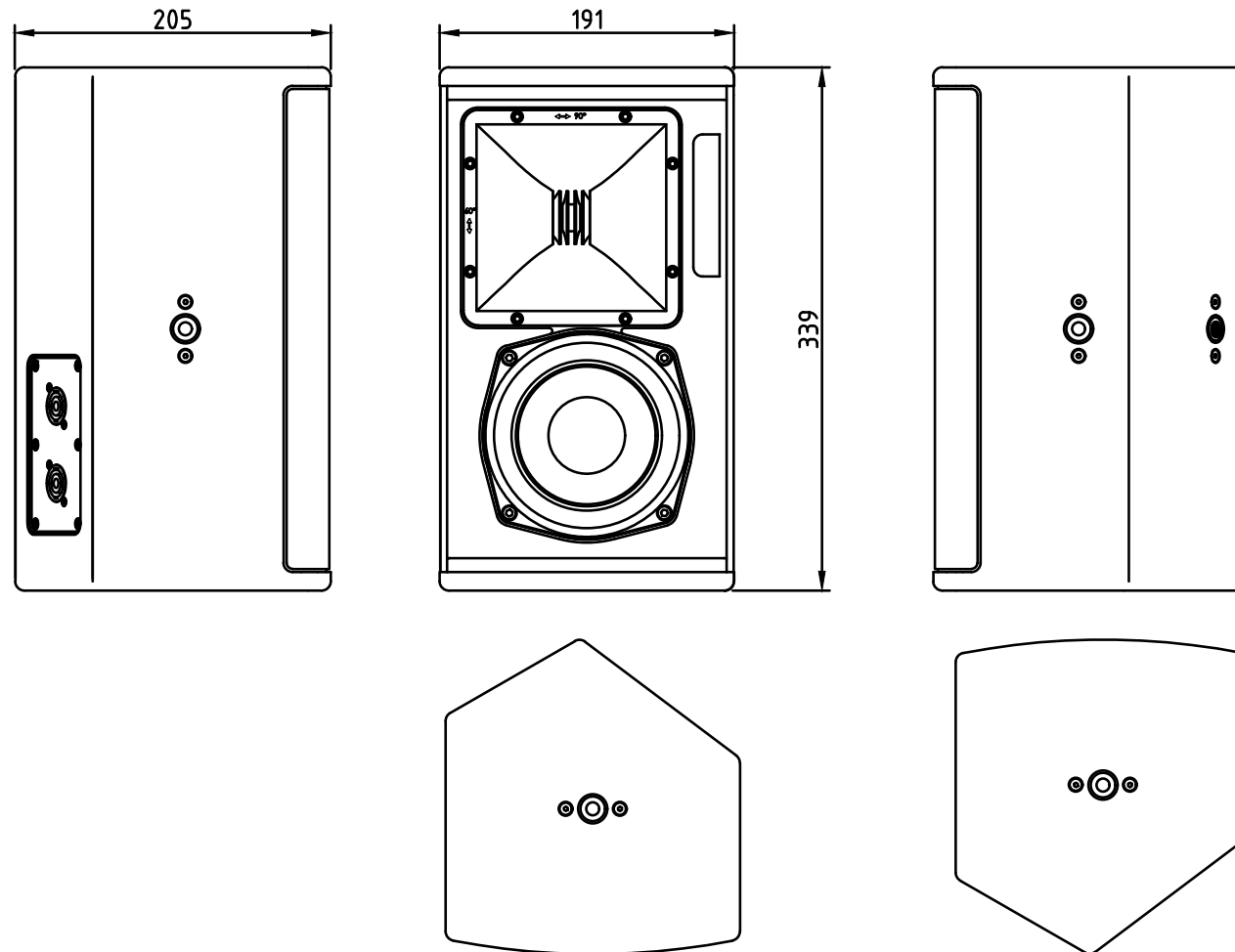

Drawing not to scale



# 9. Simulation

The projection performance of the VR5 can be simulated through the EASE programs. Visit [www.alconsaudio.com/simulation](http://www.alconsaudio.com/simulation) to download the GLL data set.

## VR5 Horizontal:

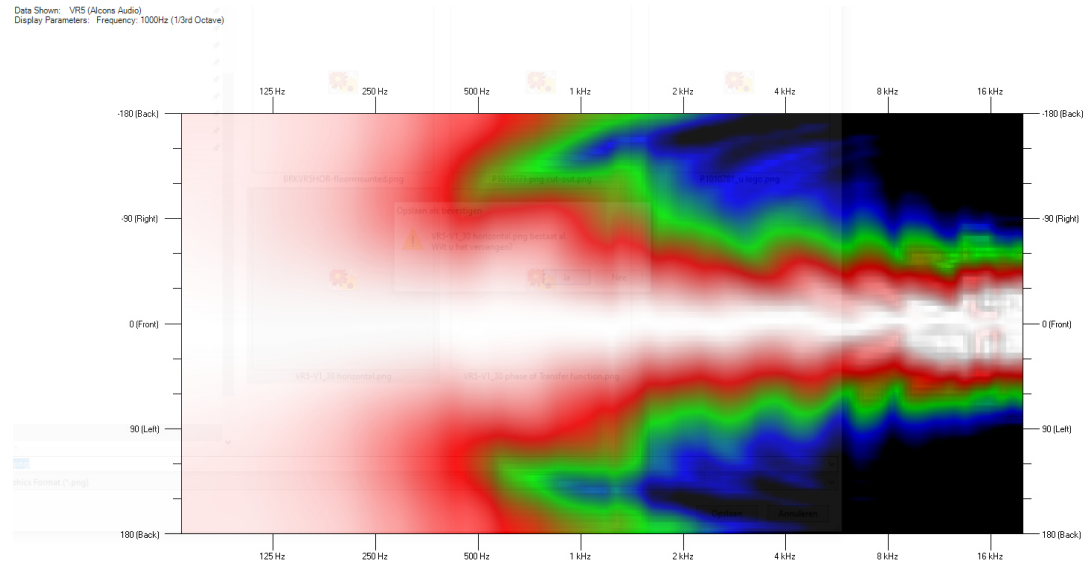

## VR5 Vertical:

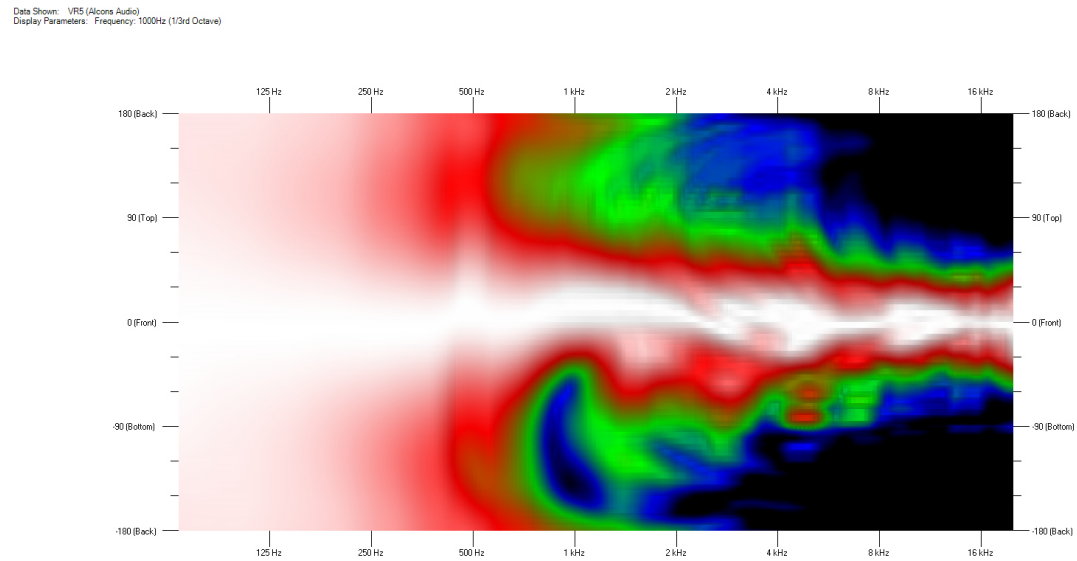

## 9. Simulation

The projection performance of the VR5 can be simulated through the EASE programs. Visit [www.alconsaudio.com/simulation](http://www.alconsaudio.com/simulation) to download the GLL data set.

### Frequency & phase response

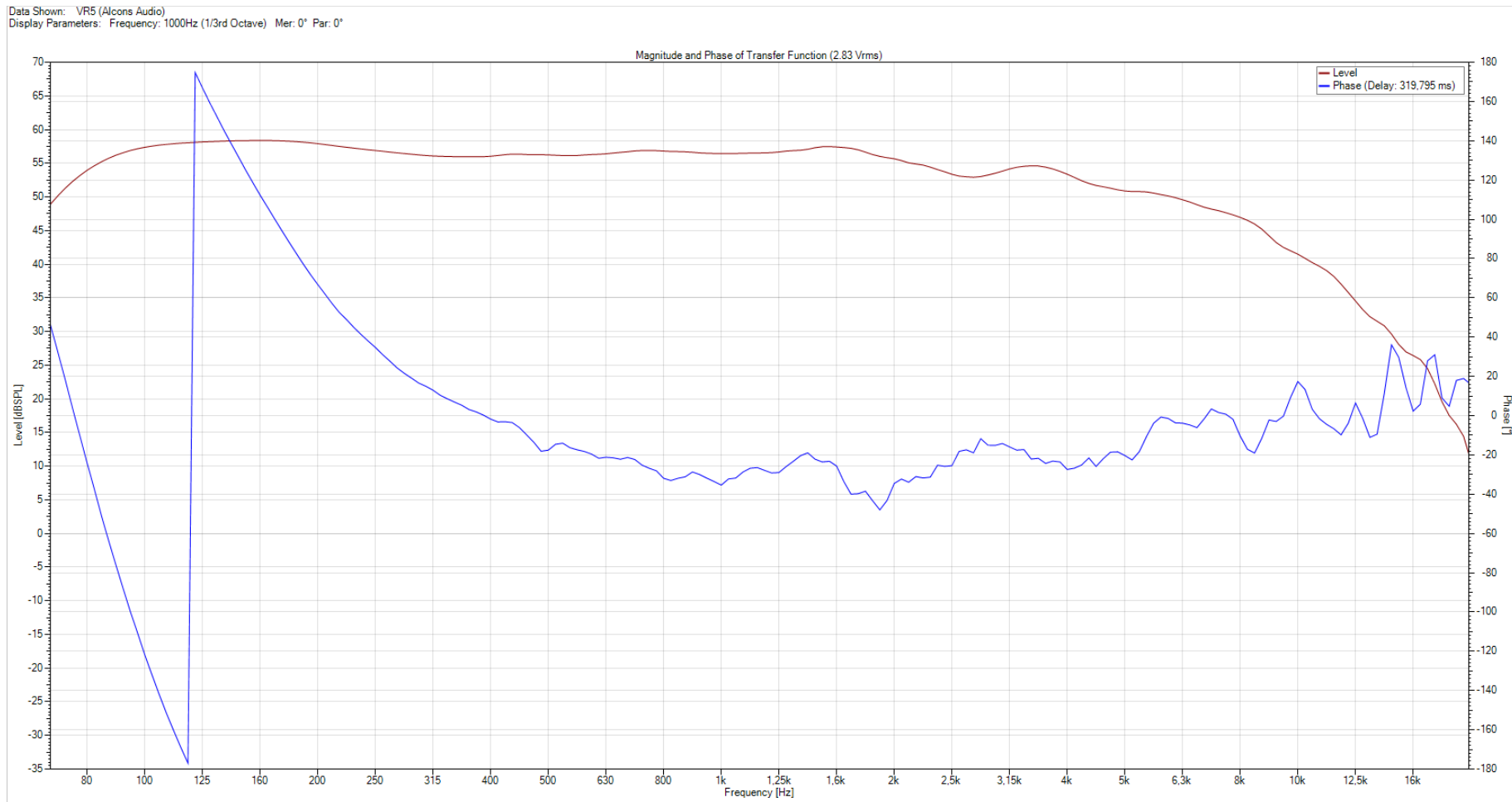

# 10: Service and support

## Warranty

### Summary

Alcons Audio BV warrants the original purchaser and any subsequent owner of each new Alcons product, for a period of six years limited from the date of the original purchase by the original purchaser, that the new Alcons product is free of defects in materials and workmanship. Alcons Audio BV warrants the new Alcons product regardless of the reason for failure, except as excluded in this warranty, you must keep the original sales receipt to establish the exact date of purchase.

### Item excluded from warranty

Warranty does not cover any product which has been damaged because of any misuse, accident, or negligence. Warranty also does not extend to a new Alcons product if the serial number has been defaced, altered or removed.

### What we will do

Alcons Audio BV will replace defective parts and repair malfunctioning products, regardless of the reason for failure (except as excluded). Warranty work can only be performed at our authorized service centres, or at our factory.

### Disclaimer

Alcons Audio BV is not liable for any damage to loudspeakers, amplifiers, or any other equipment that is caused by negligence, misuse or improper installation. Alcons Audio is not liable for any incidental damages resulting from any defect in the new Alcons product. This includes any damage to another product or products resulting from such a defect.

Alcons Audio BV reserves the right to change specifications without notice.

## 11: EC declaration of conformity

Alcons Audio BV  
De Corantijn 69  
1689 AN ZWAAG  
The Netherlands

States that the following products:

VR5  
VR5M

Are in conformity with the provisions of:

Low Voltage Directive, 2006/95/EC  
Electro-Magnetic Compatibility Directive, 2004/108/EC

Applied rules and standards:

EN60065 (Electrical Safety)  
EN55103-1 (Emission)  
EN55103-2 (Immunity)

Established at Zwaag, the Netherlands,  
July 1st, 2014

T.H. Back  
Managing Director





A: Alcons Audio HQ  
De Corantijn 69  
1689 AN, Zwaag  
The Netherlands

T: + 31 (0) 229 28 30 90  
E: [info@alconsaudio.com](mailto:info@alconsaudio.com)

A: Alcons Audio USA  
PO Box 1410  
Felton, CA 95018  
United States of America

T: +1 (949) 439-8203  
E: [info@alconsaudio.us](mailto:info@alconsaudio.us)

A: Alcons Audio GmbH  
Stargarderstraße 2  
30900 Wedemark  
Germany

T: +49 (0) 5130 586811  
E: [info@alconsaudio.de](mailto:info@alconsaudio.de)

evolutionary audio solutions™  
**alconsaudio.com**